



TRUCK BODIES

A Marmon Holdings / Berkshire Hathaway Company

CHALLENGER PRO



CHALLENGER PRO BODY SPECIFICATIONS

Standard Construction

- Bulkhead (non-ribbed) 14 ga. galvaneal steel
- Crossmember-front.....7 ga. hot-rolled formed channels
- Crossmember-intermediateSRW: 12 ga. galvaneal steel
DRW: 10 ga. galvaneal steel
- Crossmember-rear7 ga. hot-rolled formed channels
- Compartment Bottoms 16 ga. galvaneal steel
- Compartment Tops 14 ga. galvaneal steel (one-piece integral w/loadspace centers)
- Doors..... 18 ga. galvaneal steel double panel
- End panels-front 14 ga. galvaneal steel
- End panels-rear..... 14 ga. galvaneal steel
- Fender panels..... 16 ga. galvaneal steel
- Floor 12 ga. embossed galvaneal treadplate
- Loadspace inside centers..... 14 ga. galvaneal steel (one-piece integral w/compartment tops)
- Intermediate panels 16 ga. galvaneal steel
- Longitudinals..... 10 ga. galvaneal formed
- Shelving..... 16 ga. high-spangle galvanized (250 lb. static load cap.)
- Tailgate..... 16 ga. galvaneal (double panel, formed construction)

STAHLL TRUCK BODIES are engineered with an innovative lock-bolt fastener design to provide unbeatable durability and eliminate rust issues from traditional welding and grinding. Floor understructures are rigidly welded for structural integrity with mounting points reinforced by U-channel gussets.

Core security features, along with a detailed view of the rugged rear tailgate.



STANDARD FEATURES

Two-Sided Zinc Coated Galvaneal Steel Construction – Utilizing American sourced steel that is expertly engineered to protect against work site conditions, Stahl truck bodies deliver the durability and strength to achieve the everyday performance demanded by the professionals across the industry.

Worksite-Ready Powder Coat Finish – Body exterior, compartment interiors, and cargo area surfaces are all finished in a corrosion resistant gloss white, polyester, TGIC powder coating and ready for work on day one.

Powder Coated Compartment Interiors – powder coated compartments to protect against rust and corrosion caused by movement of tools and materials.

Smooth Seamless Exterior Construction – Flat sides and compartment tops allowing for easy branding and decals of great looking fleet trucks.

Undercoating Protection – Applied to the underside surfaces of the bottom of floor and wheel wells to protect against rust and corrosion caused by ground debris and moisture.

Internal Compartment Door Hinges – Concealed, bolt-on style hinges provide not only a clean appearance, but increase security and remove rust points that exist in competitive external designs.

Professional T-Handle Rotation Latches – Stahl designed stainless steel T-handle compression latches create a tight seal for all door panels to protect tools against the elements of both dust and moisture.

Fully Recessed Tie-Down Rings – Stahl’s “d-ring” style tie-downs fully recess into the floor space to provide ample capacity for securing cargo without restricting load space as seen with other bodies in the industry.

Oversized Compartment Storage – Stahl provides the largest capacity tool storage in the industry. With pass-thru openings in intermediate panels between horizontal and all vertical compartments delivering full length storage, as well as bolt-in material trays and dividers, our bodies support the demand of material organization.

Automotive Style Door Seal – Stahl designed weather stripping seals tight against a flat surface for environmental protection, doubling as a drip edge for additional protection in compartments.

Gas Shock Doors – Stahl’s gas cylinder style door supports smoothly operate to hold compartment doors in the fully open position and assist in closing.

“Plug and Play” LED Rear Lighting with Wiring Harness – Stahl’s ultra bright end panel mounted 5-in-1 light kit allows for quick and easy installation, providing flexible light options for your work demands.

Rugged Rear Tailgate – Stahl’s tailgate features a heavy-duty two-point “slam-lock” system featuring innovative anti-rack/rattle hardware securing your cargo in transport.

Fender Panels – Powder coat protected bolt-on die-stamped panels with radius wheel opening and fuel fill to allow for a universal fit across chassis types.

For Customer Service Call: 1.800.277.8245
stahltruckbodies.com/contact

Continues on reverse side...

Compartment Layout

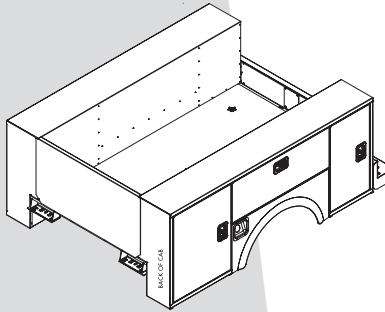

STREETSIDE

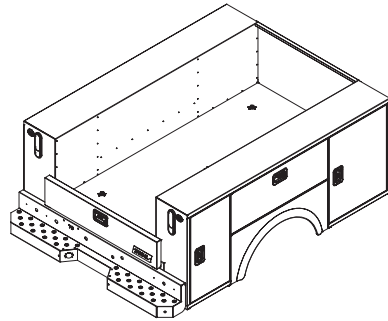

CURBSIDE

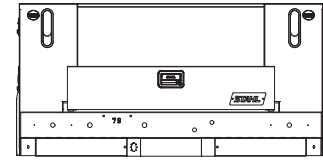

REAR VIEW
CHALLENGER PRO

Dimensional Data

	98VVS	98VVST	98VVD	110VVS	110VVD	134VVD
Overall body length (less bumper)	98"	98"	98"	110"	110"	134"
Loadspace floor width	48.5"	48.5"	52.5"	48.5"	48.5"/52.5"	48.5"/52.5"
Overall body width	79.98"	79.98"	96"	79.98"	92"/96"	92"/96"
Cab-to-axle requirement	56"	56"	56"	60"	60"	84"
Front vertical width / Clear door opening	29.81" / 23.88"			33.44" / 28.94"		33.44" / 27.50"
Second vertical width / Clear door opening	N/A			N/A		24" / 19.81"
Horizontal width / Clear door opening	47.19" / 45.31"					
Rear vertical width / Clear door opening	21" / 15.25"	21" / 15.25"	21" / 15.25"	29.75" / 25.5"	29.75" / 25.5"	29.75" / 24.06"
Vertical comp. height / Clear door opening	39.5" / 33.13"	36" / 29.63"	39.5" / 33.13"			
Horizontal comp. height / Clear door opening	18.07" / 13.19"	14.59" / 9.69"	18.07" / 13.19"			
Side compartment depth	13.84"	13.84"	19.84"	13.63"	19.63"	19.63"
Floor to compartment top height	25.5"	25.5"	25.5"	25.5"	25.5"	25.5"
Tailgate height above floor / overall height	9.10" / 11.22"					

Compartmental Tray Configurations

Streetside (Configurations)

COMPARTMENT	CURBSIDE COMPARTMENTATION	STREETSIDE COMPARTMENTATION
Front Vertical	(2) adjustable trays with dividers	(2) adjustable trays with dividers
Horizontal	(1) adjustable tray with dividers	Open
Rear Vertical	(1) adjustable tray with dividers	(1) adjustable tray with dividers

For other models and dimensional data visit our website: stahltruckbodies.com

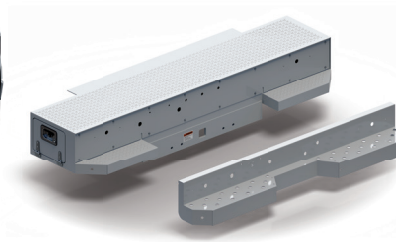

Depicted is the flip-top setup with the optional bumper package shown to the right.

STAHL

3201 W. Old Lincoln Way
Wooster, OH 44691

P: 800.277.8245 F: 330.264.0300

stahltruckbodies.com

STAHL[®]
TRUCK BODIES

A Marmon Holdings / Berkshire Hathaway Company