

BOTH HOLES WILL NEED MATCH DRILLED THROUGH THE FRAME FOR MOUNTING BRACKET INSTALL ON BOTH SIDES OF THE TRUCK.

INCLUDE A COPY OF THIS DRAWING

ITEM	QTY	DMG ID	PART NUMBER	DESCRIPTION
12	8	9270	927190	1/2" PLASTIC HOLE PLUG, GMPT BTM
11	1	0900	144403-03	PLASTIC PARTS BAG, 8" X 12"
10	4	9170	917516	SCREW 5/8-11 X 1.75 GR 8 HHCS

9	4	9170	917475	HHCS 1/2-13 X 2.00 GRD.8
8	4	9190	144736	NUT-LK-1/2-13 GR8
7	10	9170	134270	5/8-11 X 2.00 GRADE #8 HHCS
6	14	9190	919526	NUT, 5/8-11 NYLON LOCK GR 8
5	28	9190	919880	WASHER 5/8 FLAT
4	8	9190	129115	1/2 WASHER - HARDENED
3	2	4233	228808	BRACKET-2017 FORD FRNT MNTG
2	1	4233	228821-02	BRACKET-REAR MOUNTING-RH
1	1	4233	228821-01	BRACKET-REAR MOUNTING-LH

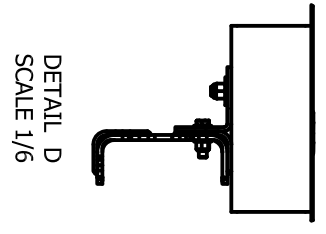
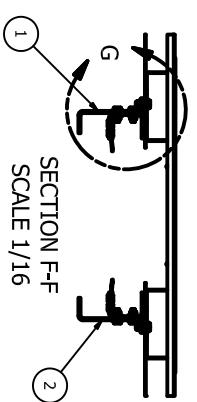
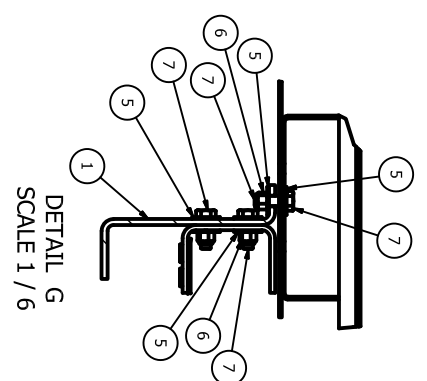
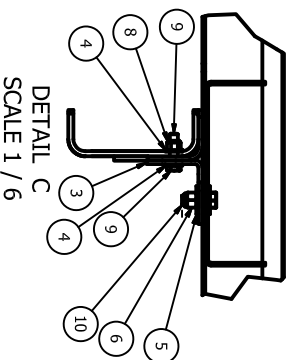

TITLE  
 CST 110 INSTALLATION-17 FORD

DATE 10-24-16  
 SCALE 1=16  
 DRAWING NO. 209370-17F-600CA

STAHLL